

# Autonics

## SCALING METER

### M4NS/M4YS SERIES

#### INSTRUCTION MANUAL



Thank you for choosing our Autonics product.  
Please read the following safety considerations before use.

### ■ Safety Considerations

- ※Please observe all safety considerations for safe and proper product operation to avoid hazards.
- ※⚠ symbol represents caution due to special circumstances in which hazards may occur.
- Warning** Failure to follow these instructions may result in serious injury or death.
- Caution** Failure to follow these instructions may result in personal injury or product damage.

### ⚠ Warning

- Fail-safe device must be installed when using the unit with machinery that may cause serious injury or substantial economic loss.** (e.g. nuclear power control, medical equipment, ships, vehicles, railways, aircraft, combustion apparatus, safety equipment, crime/disaster prevention devices, etc.)  
Failure to follow this instruction may result in fire, personal injury, or economic loss.
- Install on a device panel to use.**  
Failure to follow this instruction may result in fire.
- Do not connect, repair, or inspect the unit while connected to a power source.**  
Failure to follow this instruction may result in fire.
- Check 'Connections' before wiring.**  
Failure to follow this instruction may result in fire.
- Do not disassemble or modify the unit.**  
Failure to follow this instruction may result in fire.

### ⚠ Caution

- When connecting the power/measurement input, use AWG 24(0.20mm<sup>2</sup>) to AWG 15 (1.65mm<sup>2</sup>) cable and tighten the terminal screw with a tightening torque of 0.98 to 1.18N·m.**  
Failure to follow this instruction may result in fire or malfunction due to contact failure.
- Use the unit within the rated specifications.**  
Failure to follow this instruction may result in fire or product damage.
- Use dry cloth to clean the unit, and do not use water or organic solvent.**  
Failure to follow this instruction may result in fire.
- Do not use the unit in the place where flammable/explosive/corrosive gas, humidity, direct sunlight, radiant heat, vibration, impact, or salinity may be present.**  
Failure to follow this instruction may result in fire or explosion.
- Keep metal chip, dust, and wire residue from flowing into the unit.**  
Failure to follow this instruction may result in fire or product damage.

### ■ Ordering Information

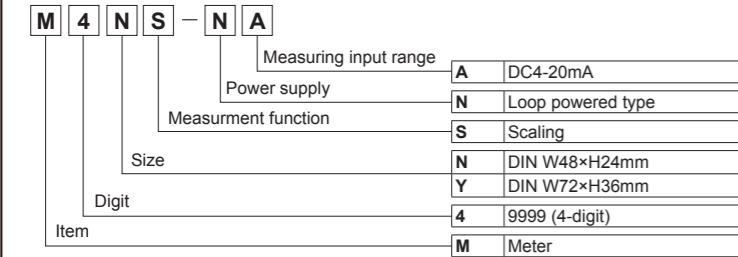

### ■ Unit Description

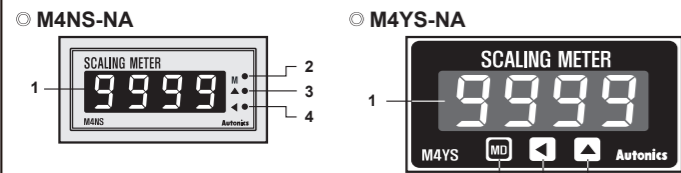

- Display value, parameter, error display
- M, [MD] key:** When enter into Parameter group, return to RUN mode, after completing Parameter setting
- ▲, [▲] key:** When enter into the status of parameter setting
- ◀, [◀] key:** When enter into the status of parameter setting and move digit

※The above specifications are subject to change and some models may be discontinued without notice.  
※Be sure to follow cautions written in the instruction manual and the technical descriptions (catalog, homepage).

### ■ Specifications

Model	M4NS-NA	M4YS-NA
Power supply	Loop powered type	
Display method	7-segment LED display (red)	
Character height	10mm	14mm
Display accuracy <sup>※1</sup>	F.S. 0.3% rdg ±1-digit	
Display cycle	0.5 sec/1 sec/2 sec/3 sec/4 sec/5 sec	
Resolution	12,000 resolution	
Max. display	-1999 to 9999	
Setting type	Setting type with the front keys	
Measuring input range <sup>※2</sup>	DC4-20mA	
Self-diagnosis function	Error display function	
Insulation resistance	Over 100MΩ (at 500VDC megger)	
Dielectric strength	2000VAC 50/60Hz for 1 min	
Vibration	Mechanical	0.75mm amplitude at frequency of 10 to 55Hz (for 1 min) in each X, Y, Z direction for 1 hour
	Malfunction	0.5mm amplitude at frequency of 10 to 55Hz (for 1 min) in each X, Y, Z direction for 10 min
Shock	Mechanical	300m/s <sup>2</sup> (approx. 30G) in each X, Y, Z direction for 3 times
	Malfunction	100m/s <sup>2</sup> (approx. 10G) in each X, Y, Z direction for 3 times
Environ-ment	Ambient temp.	-10 to 50°C, storage: -25 to 60°C
	Ambient humi.	35 to 85%RH, storage: 35 to 85%RH
Unit weight	Approx. 44g	Approx. 110g

※1: Ambient temperature (25°C ±5°C): F.S. 0.3% rdg of ±1-digit (-10 to 50°C: F.S. 0.4% rdg ±1-digit)  
 ※2: Impedance between input lines: Max. 600Ω (based on 24VDC)  
 Please be aware that activating input power is based on 24VDC, and the recommended impedance also will be lowered if the activating power is lower.  
 ※Environment resistance is rated at no freezing or condensation.

### ■ Dimensions

(unit: mm)

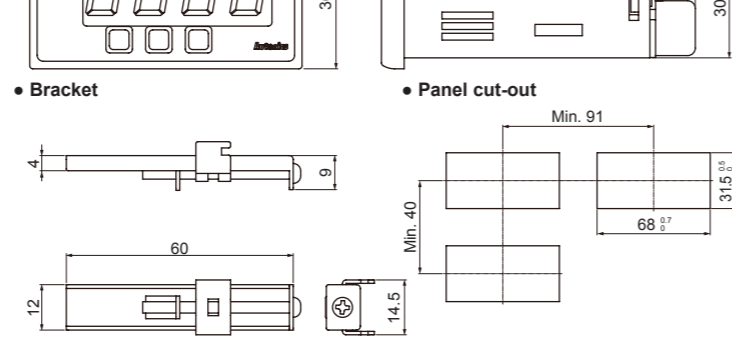
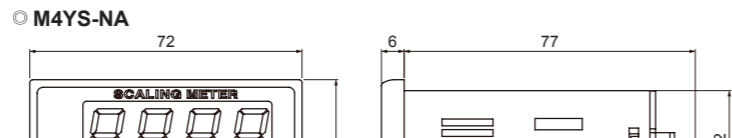
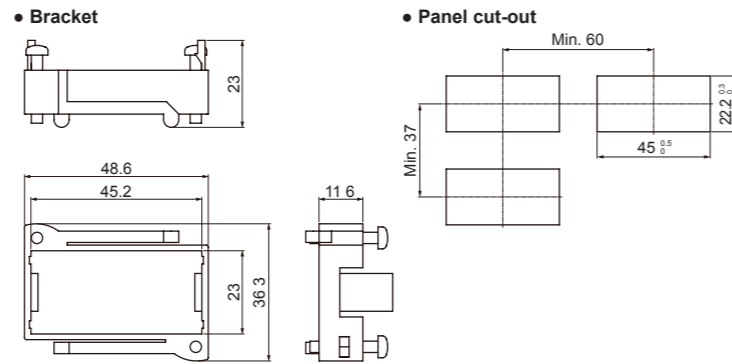
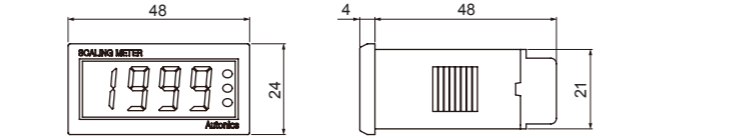

### ■ Connections

※Use terminals of size specified below.

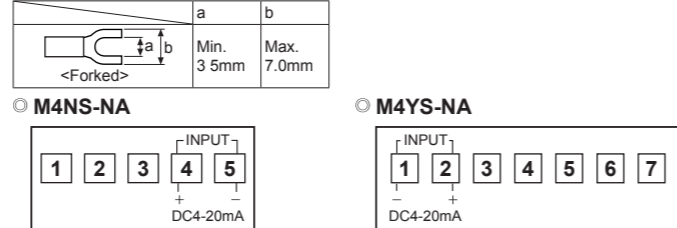

### ■ Parameter

Display	Function	Setting range	Factory default
L-5C	Low scale	Low limit display value for 4mA input	-1 999 to 9 999, -19.99 to 99.99, -199.9 to 999.9, -1999 to 9999
H-5C	High scale	High limit display value for 20mA input	2 000
dot	Decimal point	Set Decimal point position	0000, 000.0, 00.00, 0.000
l n b L	Input bias low	Correct the Low-limit value of display value (digit)	-100 to 100
l n b H	Input bias high	Correct the High-limit value of display value (%)	0.900 to 1.100
PEL t	Max./Min. time	See the Max./Min. value monitoring delay time (sec)	0 to 30
d t	Display time	Selectable sampling period (sec)	0.5, 1.0, 2.0, 3.0, 4.0, 5.0
E P C t	Error %	Set % of HHHH/LLLL display range	0, 1, 2, 3, 4
L o C	Lock	Set the lock function	ON, OFF

### ■ Display Scale Function

This function is to display the value with setting certain HI/Low limit value against DC4-20mA input. For example if set a=DC 4mA, b=DC 20mA and A,B as display value, it will be displayed a=A, b=B.

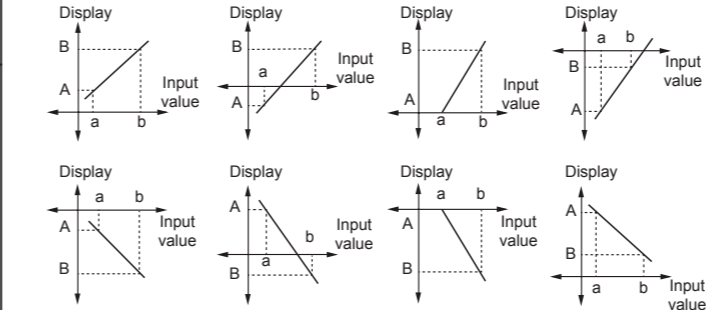

### ■ Correction Function

This function is to adjust the error of display value after calculating scale value for measuring input and also correct the input error of sensor etc.  
 l n b L: -100 to 100 [Adjust deviation of low value].  
 l n b H: 0.900 to 1.100 [Correct gradient (%) of high value]  
 E.g.) When display value is 0 to 500.0 against 4-20mA input, if the display value is "1.2" for 4mA input, set -12 (ignore the decimal point) as l n b L value to display "0.0". It is enable to remove offset of Low display value.  
 ※When completed above Low value setting then apply 20mA, if the display value is "500.5", the correction value will be 5005/5000=0.999, set 0.999 as l n b H value then enable to correct High value is 5005×0.999 = 5000. It is also ignore the decimal point.

### ■ Display Cycle Delay Function

It is difficult to display when the measuring input value is fluctuating. In this case it is able to make display value stable by delaying display cycle. Display cycle can be changed in [d t] mode of Parameter 2 (0.5s/1.0s/2.0s/3.0s/4.0s/5.0s).  
 If select [5.0], it will be the measuring input value on an average for 5sec, then display it every 5 sec

### ■ Max./Min. Value Monitoring Function

This function is to monitor Max. value and Min. value by current display value then display its Data in PELH mode and PELL mode.  
 Enable to set delay time in PEL t mode to protect the wrong Data by initial over current and settable from 0 to 30 sec and start to monitor after delay time.

### ■ Error Display Function

- Error display**
  - When [L L L L] display
    - Input current is lower than 3% in 4-20mADC (16mA scale)  
[L L L L] will display when it is under 3.52mA [16mA×3%=0.48mA] → 4mA-0.48mA=3.52mA
    - When it is beyond Min. display value (-1999)[by display value]
  - When [H H H H] display
    - Input current is higher than 3% in 4-20mADC (16mA scale)  
[H H H H] display [16mA×3%=0.48mA] → 20mA+0.48mA=20.48mA.  
When it is higher than 20.48mA.
    - When it is beyond Max. display value (9999)[by display value]
- Turn Error display off**  
[L L L L] and [H H H H] are displayed when input is out of measuring range, therefore it will be disappeared automatically when input returns to measuring range.
- Error setting and sort**  
It will display the error message according to the setting value which set % value against analog input range and set it in [E P C t] mode by [▲] key.

Display	Description
E P C t 0	LLLL / HHHH are displayed when it is over 0% out DC4-20mA range
E P C t 1	LLLL / HHHH are displayed when it is over 1% out DC4-20mA range
E P C t 2	LLLL / HHHH are displayed when it is over 2% out DC4-20mA range
E P C t 3	LLLL / HHHH are displayed when it is over 3% out DC4-20mA range
E P C t 4	L 5C / H 5C are displayed always when it is out DC4-20mA range

### ■ Parameter 0 Group (Monitoring Mode)

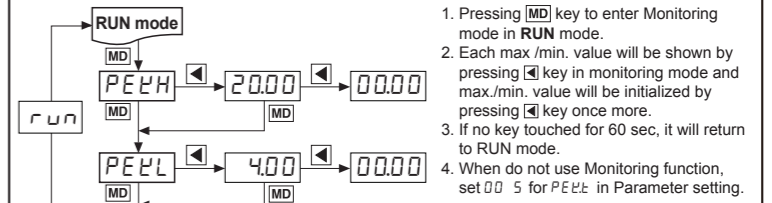

- Pressing [MD] key to enter Monitoring mode in RUN mode.
- Each max./min. value will be shown by pressing [▲] key in monitoring mode and max./min. value will be initialized by pressing [◀] key once more.
- If no key touched for 60 sec, it will return to RUN mode.
- When do not use Monitoring function, set 00 5 for PEL t in Parameter setting.

### ■ Parameter 1 Group

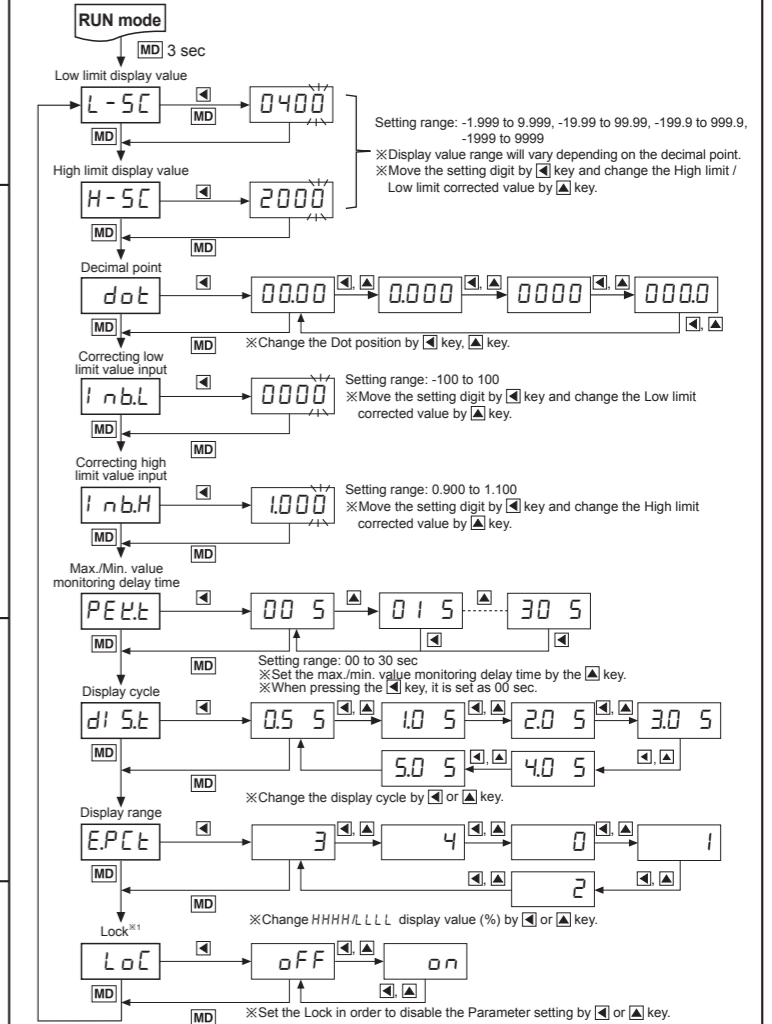

※Press the [MD] key after changing the setting value of the parameter, the setting value is saved and it moves to next parameter.  
 ※After entering setting parameter, hold the [MD] key for 3 sec, it displays [RUN] and returns to RUN mode  
 ※If any key is untouched for 60 sec, it will return to RUN mode.  
 ※1: Lock OFF: Enable to change or set Parameter.  
 ON: Disable to change or set Parameter but enable to check the setting value in parameter group.  
 Disable to enter into the status of change setting value by pressing [▲] key.

### ■ Cautions during Use

- Follow instructions in 'Cautions during Use'. Otherwise, it may cause unexpected accidents.
  - Install a power switch or circuit breaker in the easily accessible place for supplying or disconnecting the power.
  - Keep away from high voltage lines or power lines to prevent inductive noise.
- In case installing power line and input signal line closely, use line filter or varistor at power line and shielded wire at input signal line.  
 Do not use near the equipment which generates strong magnetic force or high frequency noise.

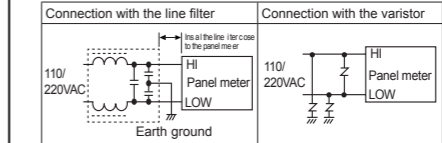

- This unit may be used in the following environments.
  - Indoors (in the environment condition rated in 'Specifications')
  - Pollution degree 2
  - Altitude max. 2,000m
  - Installation category II

### ■ Major Products

- Photoelectric Sensors
- Fiber Optic Sensors
- Door Sensors
- Door Side Sensors
- Area Sensors
- Proximity Sensors
- Pressure Sensors
- Rotary Encoders
- Connector/Sockets
- Switching Mode Power Supplies
- Control Switches/Lamps/Buzzers
- I/O Terminal Blocks & Cables
- Stepper Motors/Drivers/Motion Controllers
- Graphic/Logic Panels
- Field Network Devices
- Laser Marking System (Fiber, Co<sub>2</sub>, Nd:YAG)
- Laser Welding/Cutting System
- Temperature Controllers
- Temperature/Humidity Transducers
- SSRs/Power Controllers
- Counters
- Timers
- Panel Meters
- Tachometer/Pulse (Rate) Meters
- Display Units
- Sensor Controllers